



La Casa de los Tornillos  
de Guadalajara SA de CV

Av. Lázaro Cárdenas 107 Ote. Col Ferrocarril  
Guadalajara, Jal. México CP 44440  
CTG690201KM3  
Tel 33 3812 6655

[contacto@casatornillos.com](mailto:contacto@casatornillos.com)  
[www.casatornillos.com](http://www.casatornillos.com)

# TORNILLOS CABEZA HEXAGONAL (CAP) SAE J429 GR 5

## FICHA TÉCNICA

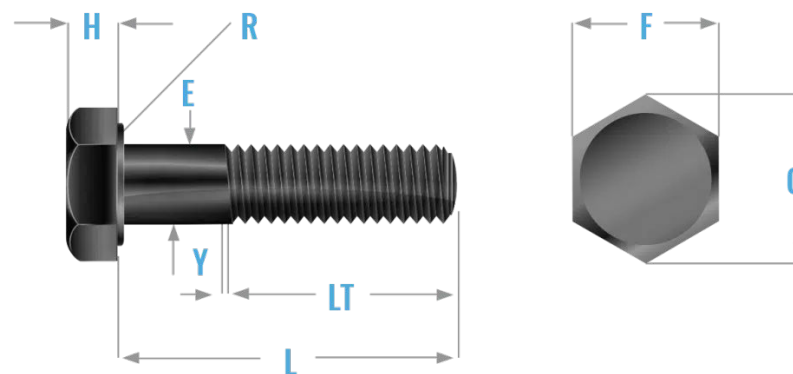

Diámetro		Diámetro del la (E)		Ancho entre caras (F)			Ancho entre rosques (G)		Altura de Cabeza (H)			Largo de rosca (LT)	
		MAX	MIN	BASICO	MAX	MIN	MAX	MIN	BASICO	MAX	MIN	<= 6"	>6"
1/4	0.25	0.2500	0.2450	7/16	0.438	0.428	0.505	0.488	5/32	0.163	0.150	0.750	1.000
5/16	0.3125	0.3125	0.3065	1/2	0.500	0.489	0.577	0.557	13/64	0.211	0.195	0.875	1.125
3/8	0.3750	0.3750	0.3690	9/16	0.562	0.551	0.650	0.628	15/64	0.243	0.226	1.000	1.250
7/16	0.4375	0.4375	0.4305	5/8	0.625	0.612	0.722	0.698	9/32	0.291	0.272	1.125	1.375
1/2	0.5000	0.5000	0.4930	3/4	0.750	0.736	0.866	0.840	5/16	0.323	0.302	1.250	1.500
9/16	0.5625	0.5625	0.5545	1 3/16	0.812	0.798	0.938	0.910	23/64	0.371	0.348	1.375	1.625
5/8	0.6250	0.6250	0.6170	1 5/16	0.938	0.922	1.083	1.051	25/64	0.403	0.378	1.500	1.750
3/4	0.75	0.7500	0.7410	1 1/8	1.125	1.100	1.299	1.254	15/32	0.483	0.455	1.750	2.000
7/8	0.8750	0.8750	0.8660	1 5/16	1.312	1.285	1.516	1.465	35/64	0.563	0.531	2.000	2.250



[WWW.CASATORNILLOS.COM](http://WWW.CASATORNILLOS.COM)

1	1	1.0000	0.99000	1 1/2	1.500	1.469	1.732	1.675	39/64	0.627	0.591	2.250	2.500
1 1/8	1.12	1.1250	1.1140	1 11/16	1.688	1.631	1.949	1.859	11/16	0.718	0.658	2.500	2.750
1 1/4	1.25	1.2500	1.2390	1 7/8	1.875	1.812	2.162	2.066	25/32	0.813	0.749	2.750	3.000
1 1/2	1.50	1.5000	1.4880	2 1/4	2.250	2.175	2.598	2.480	1 5/16	0.974	0.902	3.250	3.500

## TOLERANCIA DE LONGITUD:

Diámetro Nominal	Longitud nominal				
	Hasta 1"	Más de 1" a 2 1/2"	Más de 2 1/2" a 4"	Más de 4" a 6"	Más de 6"
1/4 - 3/8	-0.03	-0.04	-0.06	-0.10	-0.18
7/16 y 1/2	-0.03	-0.06	-0.08	-0.10	-0.18
9/16 - 3/4	-0.03	-0.08	-0.10	-0.10	-0.18
7/8 y 1	-	-0.10	-0.14	-0.16	-0.20
1 1/8 - 1 1/2	-	-0.12	-0.16	-0.18	-0.22



	<b>Grado 5</b>
<b>Aplicaciones</b>	Mayor Resistencia a la tracción que el Grado 2, la relación entre el rendimiento y la tracción es la más bajade todos los aceros con tratamiento térmico.
<b>Material</b>	Acero medio carbono, tratamiento térmico.
<b>Tratamiento térmico</b>	Tratamiento térmico templado en aceite o agua a 800° F mínimo.
<b>Dureza</b>	Consultar siguiente fila
<b>Dureza en el Nucleo</b>	1/4" – 1" D. C25-C34 Rockwell 1 1/8" – 1 1/2" D. Todas las longitudes: C19-C30 Rockwell
<b>Dureza superficial</b>	1/4" – 1" D. Todas las longitudes: 30N54 max. 1 1/8" – 1 1/2" D. Todas las longitudes: 30N50 max.
<b>Carga de prueba</b>	1/4"-1" D, todas las longitudes: 85,000 psi 1-1/8"-1-1/2" D, todas las longitudes: 74,000 psi
<b>Fuerza de Rendimiento</b>	1/4"-1" D, todas las longitudes: 92,000 psi min 1-1/8"-1-1/2" D, todas las longitudes: 81,000 psi min
<b>Resistencia a la tracción</b>	1/4"-1" D, todas las longitudes: 120,000 psi min 1-1/8"-1-1/2" D, Todas las longitudes: 105,000 psi min
<b>Alargamiento</b>	14% min
<b>Reducción del área</b>	35% min

