



La Casa de los Tornillos
de Guadalajara SA de CV

Av. Lázaro Cárdenas 107 Ote. Col Ferrocarril
Guadalajara, Jal. México CP 44440
CTG690201KM3
Tel 33 3812 6655

contacto@casatornillos.com
www.casatornillos.com

OPRESOR ALLEN ASTM F912

FICHA TÉCNICA

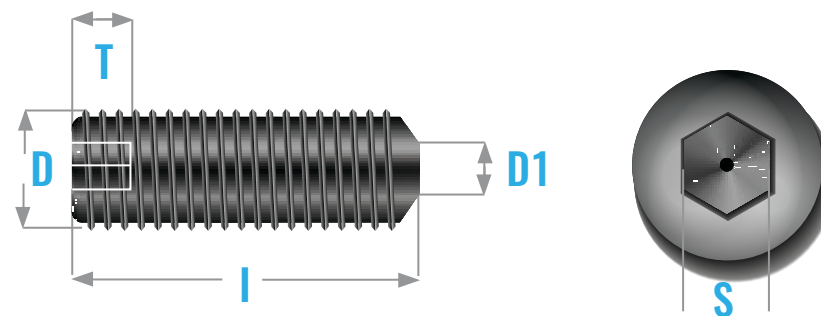

d	s	t	s
1/4	3/32	0.125	0.132
5/16	1/8	0.156	0.172
3/8	3/16	0.188	0.212
7/16	7/32	0.219	0.252
1/2	1/4	0.250	0.291
5/8	5/16	0.312	0.371
3/4	3/8	0.375	0.450

TOLERANCIA DE LONGITUD:



WWW.CASATORNILLOS.COM